

CHF 464 D

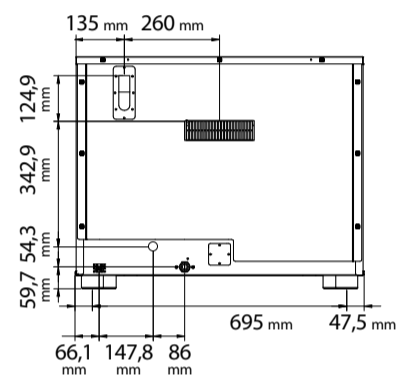

DIGITAL ELECTRIC CONVECTION OVEN WITH HUMIDIFICATION

Practical instrument suitable for medium venues to prepare the snack. Equipped with an electronic control panel with 99 programs that allow you to cook in 4 cooking stages. Customizable cooking thanks to the humidification function via button.

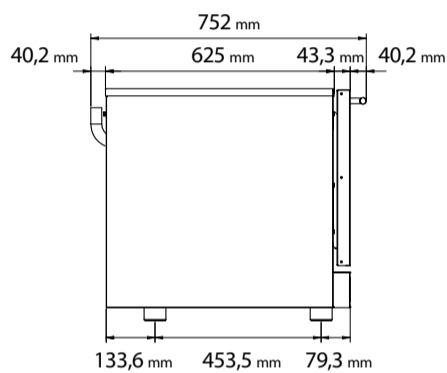
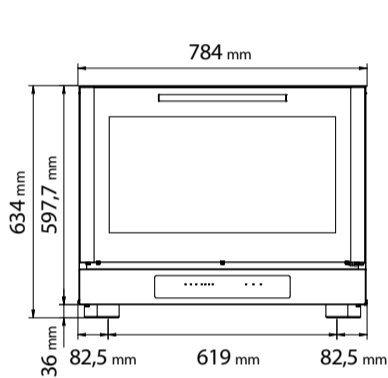

DIMENSIONAL FEATURES

| | | | |
|----------------------------------|-----|------|-----|
| Oven dimensions (WxDxH mm) | 784 | 752 | 634 |
| Oven weight (kg) | | 50,6 | |
| Distance between rack rails (mm) | | 73 | |

ELECTRICAL FEATURES

| | |
|--------------------------|------------------|
| Power supply (kW) | 3,4 |
| Frequency (Hz) | 50/60 |
| Voltage (Volt) | AC 220/230 |
| N° of motors | 2 Unidirectional |
| Boiler | / |
| Protection against water | IPX3 |

EQUIPMENT

| | | | |
|---|-----------------------------------|-----|-----|
| Cardboard box dimensions with pallet (WxDxH mm) | 805 | 830 | 800 |
| Lateral supports | 1 right + 1 left | | |
| Cable | Single-Phase [3G 1,5] - L=1350 mm | | |

FUNCTIONAL FEATURES

| | |
|----------------------------|---|
| Power | Electricity |
| Capacity | N° 4 Trays/Grids (600x400 mm) |
| Type of cooking | Ventilated |
| Humidification | Indirect with button |
| Cooking chamber | AISI 430 Stainless Steel |
| Temperature | 50 ÷ 270°C |
| Temperature control | Digital probe thermometer |
| Control panel | Digital - Lower side |
| N° of programs | 99 |
| Programmable cooking steps | 4 |
| Pre-heating temperature | 180°C |
| Pre-heating function | Available only in "Program Mode" |
| Door | Tilt door Ventilated Inspectionable glass |

PLUS

| |
|--------------------------------------|
| Stainless steel cooking chamber |
| Door with inspectionable glass |
| Quick fastening of lateral supports |
| Embedded gasket |
| Stackable |
| Forced cooling system of inner parts |
| IPX 3 |
| New design of cooking chamber |
| CB certification |
| New design of handle |