

CHF 464 D AL UD

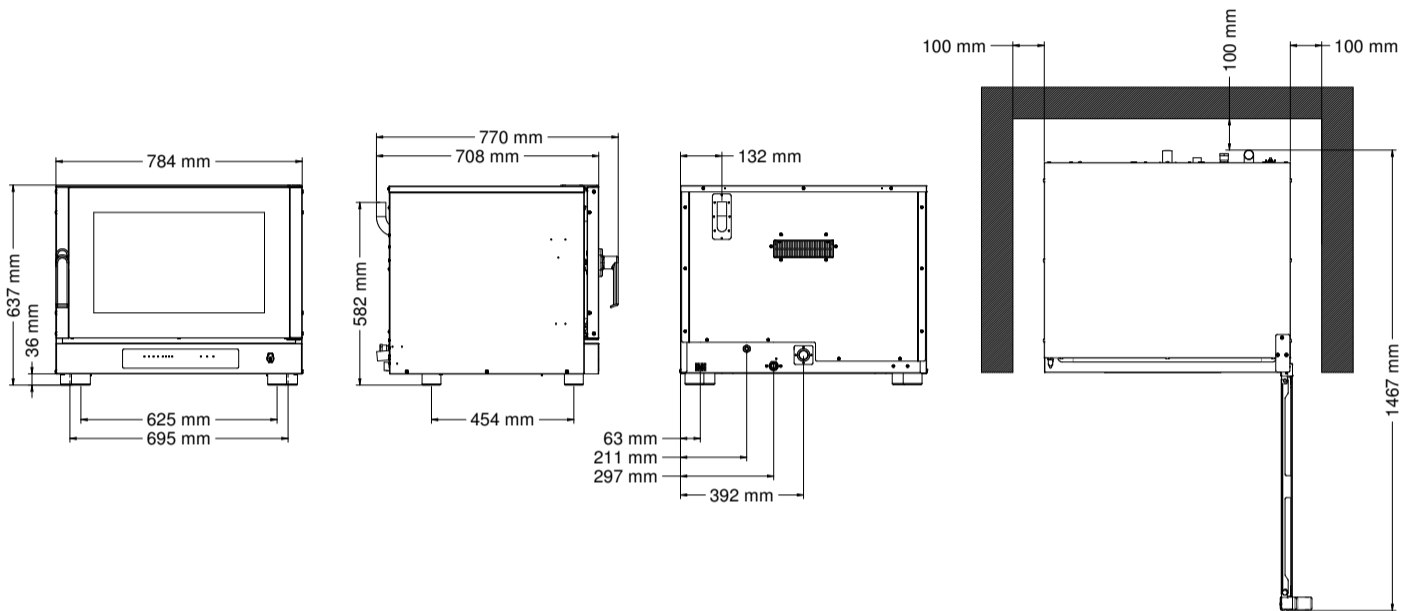

ELECTRIC COMBI OVEN WITH DIGITAL CONTROL

A blend of all-Italian technology and quality. Cakes, sweet snacks, plain or filled croissants: with the direct steam option you really can customize how each dish is baked. You control the oven with its innovative digital control panel, which has 99 programs, allowing you to cook in 4 stages, setting the time, temperature, humidity level and core probe temperature for each.



DIMENSIONAL FEATURES			
Oven dimensions (WxDxH mm)	784	770	637
Oven weight	56,2		
Distance between rack rails (mm)	83		

ELECTRICAL FEATURES	
Power supply (kW)	6,4
Frequency (Hz)	50/60
Voltage (Volt)	AC 380/400 2N
N° of motors	2 Bidirectional
Boiler	/
Protection against water	IPX3

EQUIPMENT			
Cardboard box dimensions with pallet (WxDxH mm)	805	830	800
Lateral supports	1 right + 1 left		
Cable	Two-Phase + neutral [5G 2,5] - L=1600 mm		
Manual washing set up			

FUNCTIONAL FEATURES	
Power	Electricity
Capacity	N° 4 Trays/Grids (600x400 mm)
Type of cooking	Ventilated
Steam	Direct steam controlled by digital panel (10 levels)
Cooking chamber	AISI 304 Stainless Steel
Temperature	50 ÷ 270°C
Temperature control	Digital probe thermometer
Control panel	Digital - Lower side
N° of programs	99
Programmable cooking steps	4
Pre-heating temperature	180°C
Pre-heating function	Available only in "Program Mode"
Door	Right side opening Ventilated Inspectionable glass
Modularity	Available

PLUS	
Stainless steel cooking chamber	
Door with inspectionable glass	
Quick fastening of lateral supports	
Embedded gasket	
Stackable	
Forced cooling system of inner parts	
IPX 3	
Manual washing set up	
New design of cooking chamber	
CB certification	
New design of handle	