

CHF 711 UD

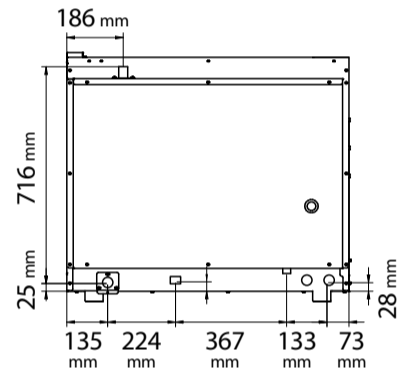

ELECTRIC COMBI OVEN

Designed and engineered for medium-sized delicatessens and restaurants requiring an oven that packs professional performance into a space-saving package. Baked pasta, meat and fish roasts and chickens, as well as particularly delicate dishes, such as restaurant desserts and meats that need slow cooking. With the direct steam option, you can customize how you cook each dish, enjoying the opportunity to give your imagination free rein.

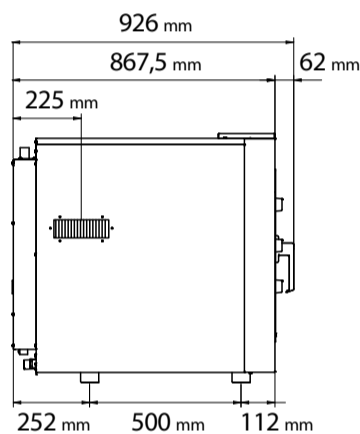
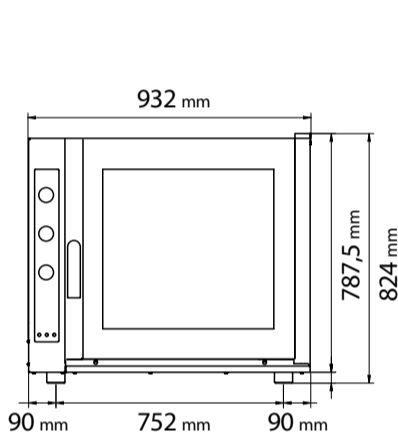

DIMENSIONAL FEATURES

Oven dimensions (WxDxH mm)	932	926	824
Oven weight (kg)	96,4		
Distance between rack rails (mm)	68		

ELECTRICAL FEATURES

Power supply (kW)	8,4
Frequency (Hz)	50 (60 on demand)
Voltage (Volt)	AC 380/400 3N
N° of motors	2 Bidirectional
Boiler	/
Protection against water	IPX3

EQUIPMENT

Cardboard box dimensions with pallet (WxDxH mm)	1000	990	990
Lateral supports	1 right + 1 left		
Cable	Three-phase + Neutral [5G 2,5] L=1600 mm		
Manual washing set up			
Removable drip box			

FUNCTIONAL FEATURES

Power	Electricity
Capacity	N° 7 trays/grids 1/1 GN
Type of cooking	Ventilated
Steam	Direct steam controlled by knob (5 levels)
Cooking chamber	AISI 304 Stainless steel
Temperature	100 ÷ 275°C
Temperature control	Thermostat
Control panel	Electromechanic - Left side
N° of programs	/
Programmable cooking steps	/
Pre-heating temperature	/
Pre-heating function	/
Door	Right side opening Ventilated Inspectionable glass

PLUS

Stainless steel cooking chamber
Door with inspectionable glass
Adjustable door hinges
Quick fastening of lateral supports
Embedded gasket
Stackable
Forced cooling system of inner parts
IPX 3
Manual washing set up
New design of cooking chamber
CB certification